

# **444H, 544H Loader TC44H, TC54H Tool Carrier Repair**

## **REPAIR TECHNICAL MANUAL 444H, 544H Loader TC44H, TC54H Tool Carrier**

**TM1605 02JUL19 (ENGLISH)**

**Worldwide Construction  
And Forestry Division**  
PRINTED IN U.S.A.

# Introduction

## Foreword

This manual is written for an experienced technician. Essential tools required in performing certain service work are identified in this manual and are recommended for use.

Live with safety: Read the safety messages in the introduction of this manual and the cautions presented throughout the text of the manual.

 This is the safety-alert symbol. When you see this symbol on the machine or in this manual, be alert to the potential for personal injury.

Technical manuals are divided in two parts: repair and operation and tests. Repair sections tell how to repair the components. Operation and tests sections help you identify the majority of routine failures quickly.

Information is organized in groups for the various components requiring service instruction. At the beginning of each group are summary listings of all applicable essential tools, service equipment and tools, other materials needed to do the job, service parts kits, specifications, wear tolerances, and torque values.

Technical Manuals are concise guides for specific machines. They are on-the-job guides containing only the vital information needed for diagnosis, analysis, testing, and repair.

Fundamental service information is available from other sources covering basic theory of operation, fundamentals of troubleshooting, general maintenance, and basic type of failures and their causes.

DX, TMIFC -19-15APR14-1/1



*Introduction*

# Contents

## Section 00—General Information

- Group 0001—Safety Information
- Group 0002—General Specifications
- Group 0003—Torque Values
- Group 0004—Fuels and Lubricants

## Section 01—Wheels

- Group 0110—Powered Wheels and Fasteners

## Section 02—Axles and Suspension Systems

- Group 0200—Removal and Installation
- Group 0225—Axle Shafts and U-Joints
- Group 0250—Axle Shaft, Bearings, Reduction Gears
- Group 0260—Hydraulic System

## Section 03—Transmission

- Group 0300—Removal and Installation
- Group 0350—Gears, Shafts, Bearings and Power Shift Clutch
- Group 0360—Hydraulic System
- Group 0399—Dealer Fabricated Tools

## Section 04—Engine

- Group 0400—Removal and Installation

## Section 05—Engine Auxiliary Systems

- Group 0505—Cold Weather Starting Aids
- Group 0510—Cooling System
- Group 0515—Speed Controls
- Group 0520—Intake System
- Group 0530—External Exhaust System
- Group 0560—External Fuel Supply Systems

## Section 07—Dampener Drive

- Group 0752—Elements

## Section 09—Steering System

- Group 0960—Hydraulic System

## Section 10—Service Brakes

- Group 1011—Active Elements
- Group 1060—Hydraulic System

## Section 11—Park Brake

- Group 1111—Active Elements
- Group 1160—Hydraulic System

## Section 16—Electrical System

- Group 1671—Batteries, Support and Cables
- Group 1672—Alternator, Regulator and Charging System Wiring
- Group 1673—Lighting System
- Group 1674—Wiring Harness and Switches
- Group 1675—System Controls
- Group 1677—Motors and Actuators

## Section 17—Frame or Supporting Structure

- Group 1740—Frame Installation
- Group 1746—Frame Bottom Guards
- Group 1749—Chassis Weights

## Section 18—Operator's Station

- Group 1800—Removal and Installation
- Group 1810—Operator Enclosure
- Group 1821—Seat and Seat Belts
- Group 1830—Heating and Air Conditioning
- Group 1899—Dealer Fabricated Tools

## Section 19—Sheet Metal and Styling

- Group 1910—Hood or Engine Enclosure
- Group 1913—Miscellaneous Shields
- Group 1921—Grille and Grille Housing
- Group 1927—Miscellaneous Shields

## Section 20—Safety and Convenience

- Group 2002—Mirror
- Group 2003—Fire Extinguisher
- Group 2004—Horn and Warning Devices

## Section 31—Loader

- Group 3102—Bucket
- Group 3140—Frames
- Group 3160—Hydraulic System

*Original Instructions. All information, illustrations and specifications in this manual are based on the latest information available at the time of publication. The right is reserved to make changes at any time without notice.*

COPYRIGHT © 2019  
DEERE & COMPANY  
Moline, Illinois  
All rights reserved.  
A John Deere ILLUSTRATION™ Manual  
Previous Editions  
Copyright © 1997, 1998, 2000, 2012, 2016

**Thanks very much for your reading,  
Want to get more information,  
Please click here, Then get the complete  
manual**

**JustClickHere** 

**NOTE:**

**If there is no response to click on the link above,  
please download the PDF document first, and then  
click on it.**

**Have any questions please write to me:  
[admin@servicemanualperfect.com](mailto:admin@servicemanualperfect.com)**

*Contents*

## Section 00 General Information

### Contents

	Page		Page
<b>Group 0001—Safety Information</b>			
Handle Fluids Safely—Avoid		Check Oil Lines And Fittings .....	00-0003-5
Fires.....	00-0001-1	Service Recommendations for	
Prevent Battery Explosions .....	00-0001-1	O-Ring Boss Fittings.....	00-0003-5
Prepare for Emergencies.....	00-0001-1	Service Recommendations For	
Prevent Acid Burns.....	00-0001-2	Flat Face O-Ring Seal Fittings .....	00-0003-7
Handle Chemical Products Safely.....	00-0001-2	Service Recommendations for	
Avoid High-Pressure Fluids .....	00-0001-3	Metric Series Four Bolt Flange	
Park Machine Safely.....	00-0001-3	Fitting .....	00-0003-8
Support Machine Properly .....	00-0001-3	Service Recommendations For	
Wear Protective Clothing.....	00-0001-4	Inch Series Four Bolt Flange	
Work in Clean Area .....	00-0001-4	Fittings .....	00-0003-9
Service Machines Safely .....	00-0001-4	<b>Group 0004—Fuels and Lubricants</b>	
Work In Ventilated Area.....	00-0001-5	Diesel Fuel.....	00-0004-1
Illuminate Work Area Safely .....	00-0001-5	Lubricity of Diesel Fuels .....	00-0004-1
Replace Safety Signs .....	00-0001-5	Low Sulfur Diesel Fuel	
Use Proper Lifting Equipment.....	00-0001-6	Conditioner .....	00-0004-1
Remove Paint Before Welding or		Diesel Fuel Storage.....	00-0004-2
Heating .....	00-0001-6	Fuel Tank.....	00-0004-2
Avoid Heating Near Pressurized		Diesel Engine Oil.....	00-0004-3
Fluid Lines .....	00-0001-6	Transmission, Hydraulic System,	
Keep ROPS Installed Properly .....	00-0001-7	Park Brake, and Differential Oil.....	00-0004-4
Service Tires Safely.....	00-0001-7	Grease.....	00-0004-5
Avoid Harmful Asbestos Dust.....	00-0001-8	Alternative and Synthetic	
Practice Safe Maintenance.....	00-0001-8	Lubricants .....	00-0004-5
Use Proper Tools .....	00-0001-9	Lubricant Storage .....	00-0004-5
Decommissioning — Proper		Mixing of Lubricants.....	00-0004-6
Recycling and Disposal of Fluids			
and Components .....	00-0001-9		
Live With Safety.....	00-0001-10		
<b>Group 0002—General Specifications</b>			
444H Specifications.....	00-0002-1		
Drain and Refill Capacities—444H.....	00-0002-2		
TC44H Specifications .....	00-0002-3		
Drain and Refill Capacities—TC44H .....	00-0002-4		
544H Specifications.....	00-0002-5		
Drain and Refill Capacities—544H.....	00-0002-7		
TC54H Specifications .....	00-0002-8		
Drain and Refill Capacities—TC54H .....	00-0002-10		
<b>Group 0003—Torque Values</b>			
Hardware Torque Specifications.....	00-0003-1		
ROPS Torque Specifications .....	00-0003-1		
Metric Bolt and Screw Torque			
Values.....	00-0003-2		
Additional Metric Cap Screw			
Torque Values .....	00-0003-3		
Unified Inch Bolt and Screw Torque			
Values.....	00-0003-4		



*Contents*

## Group 0001 Safety Information

### Handle Fluids Safely—Avoid Fires

When you work around fuel, do not smoke or work near heaters or other fire hazards.

Store flammable fluids away from fire hazards. Do not incinerate or puncture pressurized containers.

Make sure machine is clean of trash, grease, and debris.

Do not store oily rags; they can ignite and burn spontaneously.



TS227 —UN—15APR13

DX,FLAME -19-29SEP98-1/1

### Prevent Battery Explosions

Keep sparks, lighted matches, and open flame away from the top of battery. Battery gas can explode.

Never check battery charge by placing a metal object across the posts. Use a volt-meter or hydrometer.

Do not charge a frozen battery; it may explode. Warm battery to 16°C (60°F).



TS204 —UN—15APR13

DX,SPARKS -19-03MAR93-1/1

### Prepare for Emergencies

Be prepared if a fire starts.

Keep a first aid kit and fire extinguisher handy.

Keep emergency numbers for doctors, ambulance service, hospital, and fire department near your telephone.

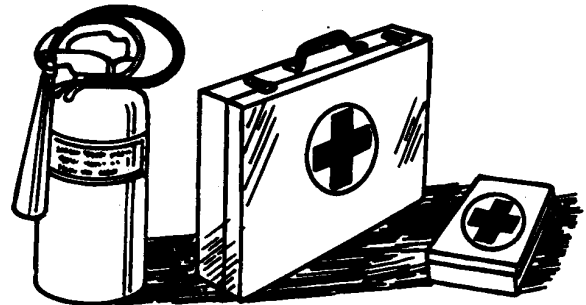

TS291 —UN—15APR13

DX,FIRE2 -19-03MAR93-1/1

## Prevent Acid Burns

Sulfuric acid in battery electrolyte is poisonous. It is strong enough to burn skin, eat holes in clothing, and cause blindness if splashed into eyes.

Avoid the hazard by:

1. Filling batteries in a well-ventilated area.
2. Wearing eye protection and rubber gloves.
3. Avoiding breathing fumes when electrolyte is added.
4. Avoiding spilling or dripping electrolyte.
5. Use proper jump start procedure.

If you spill acid on yourself:

1. Flush your skin with water.
2. Apply baking soda or lime to help neutralize the acid.
3. Flush your eyes with water for 15—30 minutes. Get medical attention immediately.

If acid is swallowed:

1. Do not induce vomiting.
2. Drink large amounts of water or milk, but do not exceed 2 L (2 quarts).
3. Get medical attention immediately.

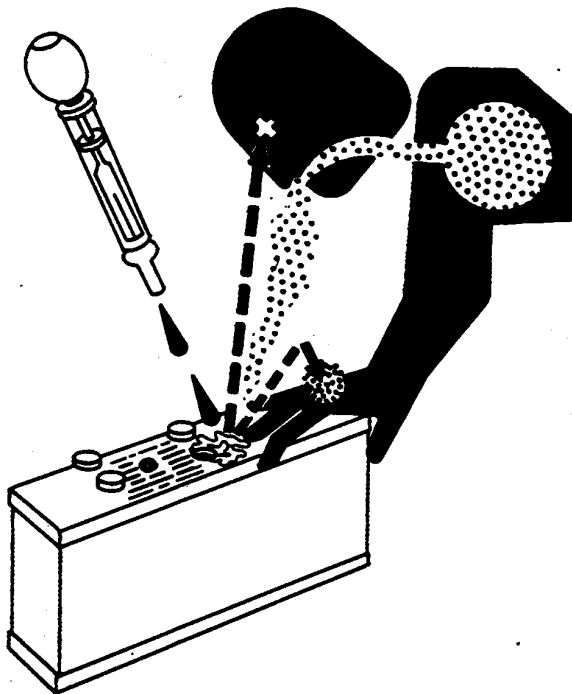

TS203—UN—23AUG88

DX,POISON -19-21APR93-1/1

## Handle Chemical Products Safely

Direct exposure to hazardous chemicals can cause serious injury. Potentially hazardous chemicals used with John Deere equipment include such items as lubricants, coolants, paints, and adhesives.

A Material Safety Data Sheet (MSDS) provides specific details on chemical products: physical and health hazards, safety procedures, and emergency response techniques.

Check the MSDS before you start any job using a hazardous chemical. That way you will know exactly what the risks are and how to do the job safely. Then follow procedures and recommended equipment.

(See your John Deere dealer for MSDS's on chemical products used with John Deere equipment.)

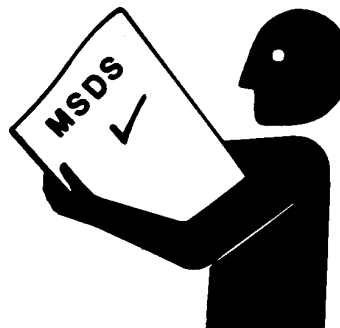

TS1132—UN—15APR13

DX,MSDS,NA -19-03MAR93-1/1

## Safety Information

### Avoid High-Pressure Fluids

Inspect hydraulic hoses periodically – at least once per year – for leakage, kinking, cuts, cracks, abrasion, blisters, corrosion, exposed wire braid or any other signs of wear or damage.

Replace worn or damaged hose assemblies immediately with John Deere approved replacement parts.

Escaping fluid under pressure can penetrate the skin causing serious injury.

Avoid the hazard by relieving pressure before disconnecting hydraulic or other lines. Tighten all connections before applying pressure.

Search for leaks with a piece of cardboard. Protect hands and body from high-pressure fluids.

If an accident occurs, see a doctor immediately. Any fluid injected into the skin must be surgically removed within a few hours or gangrene may result. Doctors unfamiliar

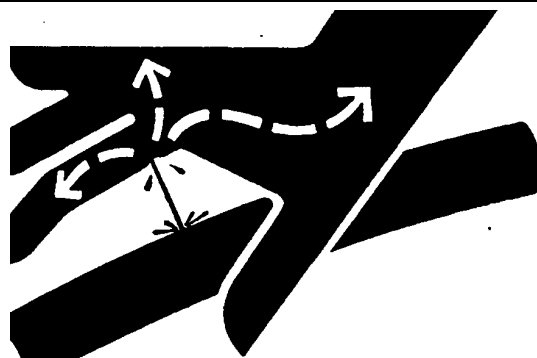

with this type of injury should reference a knowledgeable medical source. Such information is available in English from Deere & Company Medical Department in Moline, Illinois, U.S.A., by calling 1-800-822-8262 or +1 309-748-5636.

DX,FLUID -19-12OCT11-1/1

X9811 —UN—23AUG88

### Park Machine Safely

Before working on the machine:

- Lower all equipment to the ground.
- Stop the engine and remove the key.
- Disconnect the battery ground strap.
- Hang a "DO NOT OPERATE" tag in operator station.

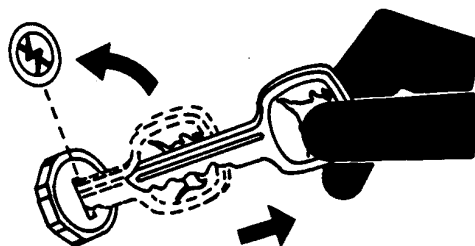

DX,PARK -19-04JUN90-1/1

TS230 —UN—24MAY89

### Support Machine Properly

Always lower the attachment or implement to the ground before you work on the machine. If the work requires that the machine or attachment be lifted, provide secure support for them. If left in a raised position, hydraulically supported devices can settle or leak down.

Do not support the machine on cinder blocks, hollow tiles, or props that may crumble under continuous load. Do not work under a machine that is supported solely by a jack. Follow recommended procedures in this manual.

When implements or attachments are used with a machine, always follow safety precautions listed in the implement or attachment operator's manual.

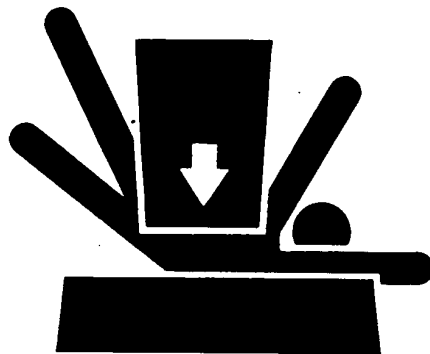

DX,LOWER -19-24FEB00-1/1

TS229 —UN—23AUG88

## Safety Information

### Wear Protective Clothing

Wear close fitting clothing and safety equipment appropriate to the job.

Operating equipment safely requires the full attention of the operator. Do not wear radio or music headphones while operating machine.

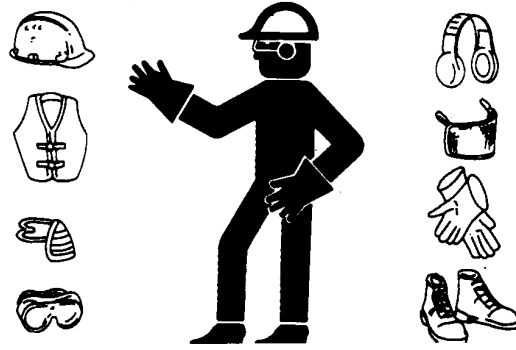

TS206 —UN—15APR13

DX,WEAR2 -19-03MAR93-1/1

### Work in Clean Area

Before starting a job:

- Clean work area and machine.
- Make sure you have all necessary tools to do your job.
- Have the right parts on hand.
- Read all instructions thoroughly; do not attempt shortcuts.

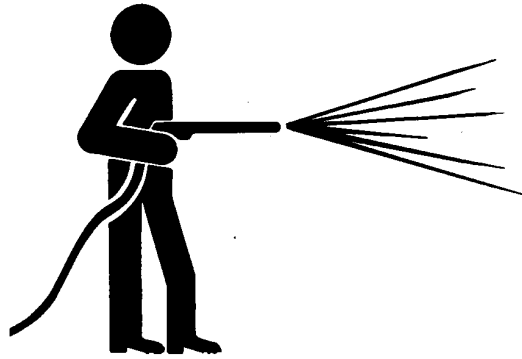

T6642EJ —UN—18OCT88

DX,CLEAN -19-04JUN90-1/1

### Service Machines Safely

Tie long hair behind your head. Do not wear a necktie, scarf, loose clothing, or necklace when you work near machine tools or moving parts. If these items were to get caught, severe injury could result.

Remove rings and other jewelry to prevent electrical shorts and entanglement in moving parts.

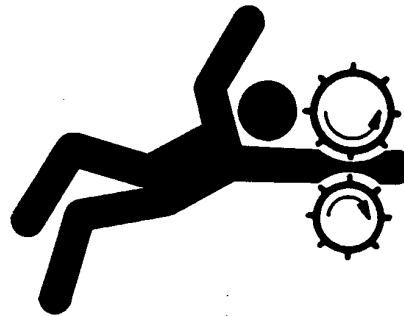

TS228 —UN—23AUG88

DX,LOOSE -19-04JUN90-1/1

## Safety Information

### Work In Ventilated Area

Engine exhaust fumes can cause sickness or death. If it is necessary to run an engine in an enclosed area, remove the exhaust fumes from the area with an exhaust pipe extension.

If you do not have an exhaust pipe extension, open the doors and get outside air into the area.



TS220 —UN—15APR13

DX,AIR -19-17FEB99-1/1

### Illuminate Work Area Safely

Illuminate your work area adequately but safely. Use a portable safety light for working inside or under the machine. Make sure the bulb is enclosed by a wire cage. The hot filament of an accidentally broken bulb can ignite spilled fuel or oil.



TS223 —UN—23AUG88

DX,LIGHT -19-04JUN90-1/1

### Replace Safety Signs

Replace missing or damaged safety signs. See the machine operator's manual for correct safety sign placement.



TS201 —UN—15APR13

DX,SIGNS1 -19-04JUN90-1/1

### Use Proper Lifting Equipment

Lifting heavy components incorrectly can cause severe injury or machine damage.

Follow recommended procedure for removal and installation of components in the manual.

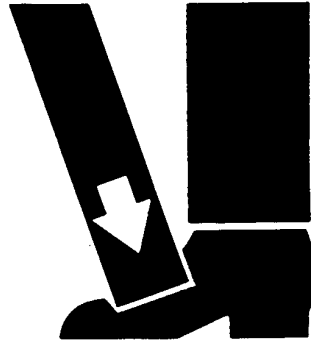

TS226 —UN—23AUG88

DX,LIFT -19-04JUN90-1/1

### Remove Paint Before Welding or Heating

Avoid potentially toxic fumes and dust.

Hazardous fumes can be generated when paint is heated by welding, soldering, or using a torch.

Remove paint before heating:

- Remove paint a minimum of 100 mm (4 in.) from area to be affected by heating. If paint cannot be removed, wear an approved respirator before heating or welding.
- If you sand or grind paint, avoid breathing the dust. Wear an approved respirator.
- If you use solvent or paint stripper, remove stripper with soap and water before welding. Remove solvent or paint stripper containers and other flammable material from area. Allow fumes to disperse at least 15 minutes before welding or heating.

Do not use a chlorinated solvent in areas where welding will take place.

Do all work in an area that is well ventilated to carry toxic fumes and dust away.

Dispose of paint and solvent properly.

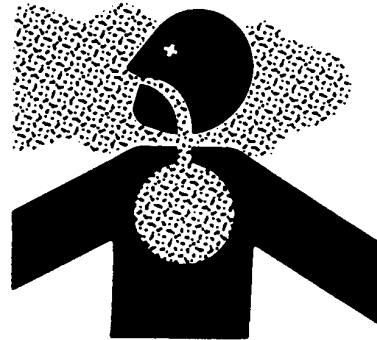

TS220 —UN—15APR13

DX,PAINT -19-24JUL02-1/1

### Avoid Heating Near Pressurized Fluid Lines

Flammable spray can be generated by heating near pressurized fluid lines, resulting in severe burns to yourself and bystanders. Do not heat by welding, soldering, or using a torch near pressurized fluid lines or other flammable materials. Pressurized lines can accidentally burst when heat goes beyond the immediate flame area.



TS953 —UN—15MAY90

DX,TORCH -19-10DEC04-1/1

### Keep ROPS Installed Properly

Make certain all parts are reinstalled correctly if the roll-over protective structure (ROPS) is loosened or removed for any reason. Tighten mounting bolts to proper torque.

The protection offered by ROPS will be impaired if ROPS is subjected to structural damage, is involved in an overturn incident, or is in any way altered by welding, bending, drilling, or cutting. A damaged ROPS should be replaced, not reused.

The seat is part of the ROPS safety zone. Replace only with John Deere seat approved for your tractor.

Any alteration of the ROPS must be approved by the manufacturer.

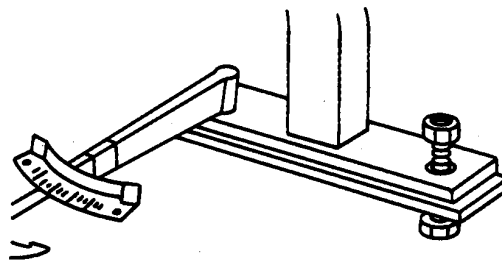

TS212—UN—23AUG88

DX,ROPS3 -19-12OCT11-1/1

### Service Tires Safely

Explosive separation of a tire and rim parts can cause serious injury or death.

Do not attempt to mount a tire unless you have the proper equipment and experience to perform the job.

Always maintain the correct tire pressure. Do not inflate the tires above the recommended pressure. Never weld or heat a wheel and tire assembly. The heat can cause an increase in air pressure resulting in a tire explosion. Welding can structurally weaken or deform the wheel.

When inflating tires, use a clip-on chuck and extension hose long enough to allow you to stand to one side and NOT in front of or over the tire assembly. Use a safety cage if available.

Check wheels for low pressure, cuts, bubbles, damaged rims or missing lug bolts and nuts.

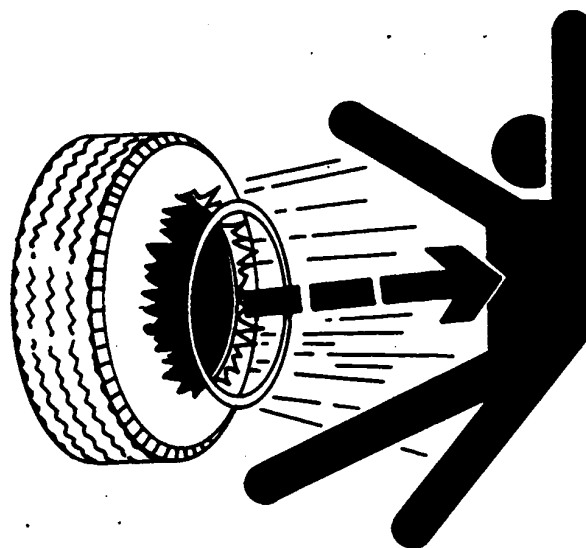

TS211—UN—15APR13

DX,RIM -19-24AUG90-1/1



### Avoid Harmful Asbestos Dust

Avoid breathing dust that may be generated when handling components containing asbestos fibers. Inhaled asbestos fibers may cause lung cancer.

Components in products that may contain asbestos fibers are brake pads, brake band and lining assemblies, clutch plates, and some gaskets. The asbestos used in these components is usually found in a resin or sealed in some way. Normal handling is not hazardous as long as airborne dust containing asbestos is not generated.

Avoid creating dust. Never use compressed air for cleaning. Avoid brushing or grinding material containing asbestos. When servicing, wear an approved respirator. A special vacuum cleaner is recommended to clean asbestos. If not available, apply a mist of oil or water on the material containing asbestos.



Keep bystanders away from the area.

TS220—UN—15APR13

DX,DUST -19-15MAR91-1/1

### Practice Safe Maintenance

Understand service procedure before doing work. Keep area clean and dry.

Never lubricate, service, or adjust machine while it is moving. Keep hands, feet, and clothing away from power-driven parts. Disengage all power and operate controls to relieve pressure. Lower equipment to the ground. Stop the engine. Remove the key. Allow machine to cool.

Securely support any machine elements that must be raised for service work.

Keep all parts in good condition and properly installed. Fix damage immediately. Replace worn or broken parts. Remove any buildup of grease, oil, or debris.

On self-propelled equipment, disconnect battery ground cable (-) before making adjustments on electrical systems or welding on machine.

On towed implements, disconnect wiring harnesses from tractor before servicing electrical system components or welding on machine.

Falling while cleaning or working at height can cause serious injury. Use a ladder or platform to easily reach each location. Use sturdy and secure footholds and handholds.



TS218—UN—23AUG88

DX,SERV -19-28FEB17-1/1

### Use Proper Tools

Use tools appropriate to the work. Makeshift tools and procedures can create safety hazards.

Use power tools only to loosen threaded parts and fasteners.

For loosening and tightening hardware, use the correct size tools. DO NOT use U.S. measurement tools on metric fasteners. Avoid bodily injury caused by slipping wrenches.

Use only service parts meeting John Deere specifications.



TS779—UN—08NOV089

DX,REPAIR -19-17FEB99-1/1

### Decommissioning — Proper Recycling and Disposal of Fluids and Components

Safety and environmental stewardship measures must be taken into account when decommissioning a machine and/or component. These measures include the following:

- Use appropriate tools and personal protective equipment such as clothing, gloves, face shields or glasses, during the removal or handling of objects and materials.
- Follow instructions for specialized components.
- Release stored energy by lowering suspended machine elements, relaxing springs, disconnecting the battery or other electrical power, and releasing pressure in hydraulic components, accumulators, and other similar systems.
- Minimize exposure to components which may have residue from agricultural chemicals, such as fertilizers and pesticides. Handle and dispose of these components appropriately.
- Carefully drain engines, fuel tanks, radiators, hydraulic cylinders, reservoirs, and lines before recycling components. Use leak-proof containers when draining fluids. Do not use food or beverage containers.
- Do not pour waste fluids onto the ground, down a drain, or into any water source.
- Observe all national, state, and local laws, regulations, or ordinances governing the handling or disposal of waste fluids (example: oil, fuel, coolant, brake fluid);

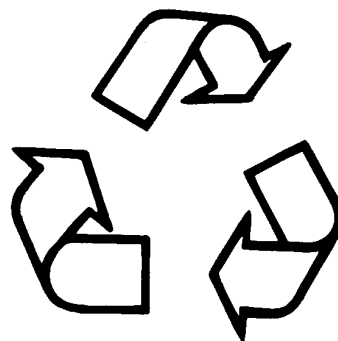

TS1133—UN—15APR13

- filters; batteries; and, other substances or parts. Burning of flammable fluids or components in other than specially designed incinerators may be prohibited by law and could result in exposure to harmful fumes or ashes.
- Service and dispose of air conditioning systems appropriately. Government regulations may require a certified service center to recover and recycle air conditioning refrigerants which could damage the atmosphere if allowed to escape.
  - Evaluate recycling options for tires, metal, plastic, glass, rubber, and electronic components which may be recyclable, in part or completely.
  - Contact your local environmental or recycling center, or your John Deere dealer for information on the proper way to recycle or dispose of waste.

DX,DRAIN -19-01JUN15-1/1

**Live With Safety**

Before returning machine to customer, make sure machine is functioning properly, especially the safety systems. Install all guards and shields.



TS231 —19—07OCT88

DX.LIVE -19-25SEP92-1/1

**444H Specifications**

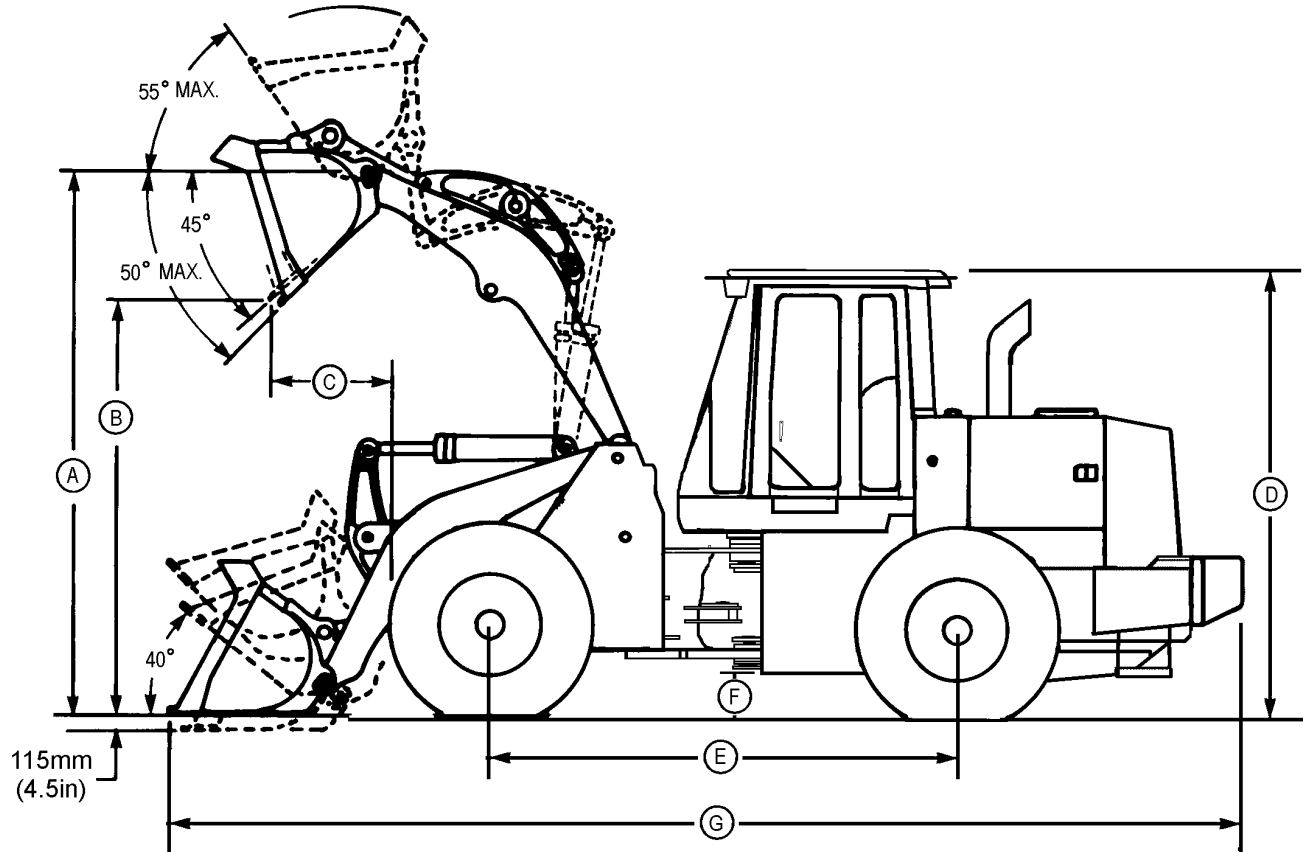

T107472

T107472—UN—19FEB97

**A—Bucket Hinge Height**  
**B—Dump Height**

**C—Dump Reach**  
**D—Overall Height**

**E—Wheelbase**  
**F—Ground Clearance**

**G—Overall Length**

Item	Measurement	Specification
Bucket Hinge	Height (A)	3682 mm (12 ft 1 in.)
Dump	Height (B)	2639 mm (8 ft 7 in.)
	Reach (C)	1094 mm (3 ft 7 in.)
Machine	Height (D)	3125 mm (10 ft 3 in.)
	Length (G)	6730 m (22 ft 1 in.)
Wheelbase	Length (E)	2750 mm (9 ft 1 in.)
Machine-to-Ground	Clearance (F)	355 mm (14 in.)
Standard Operating	Weight	9734 kg (21,460 lb)
Optional Counterweight	Weight	381 kg (840 lb)

*NOTE: Specifications and design subject to change without notice. Wherever applicable, specifications are in accordance with SAE standards. Except where otherwise noted, specifications are based on a machine equipped with all standard equipment,*

*with 381 kg (840 lb) optional counterweight, ROPS cab, diff lock front axle with standard rear axle, 2 spool valve with two lever control, heater and defroster, 79 kg (175 lb) operator and full fuel tank.*

Continued on next page

TX,115,JC1761 -19-22SEP98-1/2

## General Specifications

<b>Engine:</b>		
John Deere PowerTech® 4.5 turbocharged and aftercooled diesel	110 SAE net hp (82 kW) @ 2200 rpm	
	116 SAE gross hp (86 kW) @ 2200 rpm	
Piston displacement	4.5 L (276 cu in.)	
Air cleaner w/safety element and restriction indicator	Dual stage dry type with restriction indicator	
Electrical system	24 volt batteries 55-amp alternator	
Cold cranking capacity at -18°C (0°F)	625 amps	
Reserve capacity	160 min.	
Torque Converter	Single phase, single stage	
<b>Transmission</b>	Countershaft, computer controlled powershift	
<b>Travel Speeds:<sup>a</sup></b>		
<b>Forward Speeds:</b>	<b>km/h</b>	<b>mph</b>
1	0—7.5	0—4.6
2	0—13.4	0—8.3
3	0—24.9	0—15.5
4	0—40.0	0—24.8
<b>Reverse Speeds:</b>	<b>km/h</b>	<b>mph</b>
1	0—7.9	0—4.9
2	0—14.1	0—8.7
3	0—26.3	0—16.3

<sup>a</sup>All travel speeds are with 17.5 x 25 12PR (L2) tires.

<b>Brakes, Service:</b>	
Hydraulically-actuated, 4-wheel, inboard-mounted, wet disk	
Foot-operated, by either pedal	
Left and right pedal also disconnects transmission (if selected by operator)	
External inspection	
Low brake pressure warning light and buzzer in monitor	
<b>Brakes, Park:</b>	
Multi wet disc	
Spring applied, hydraulically released parking brake is bathed in cooling oil	
Transmission disconnects with park brake applied	
Warning light in monitor—Dual-level	
Amber lights with transmission in neutral	
Red STOP indicator lights, and buzzer sounds with transmission in gear	
<b>Steering:</b>	
Fully hydraulic. Frame articulated 80° by two hydraulic cylinders	
Turning radius (to corner of bucket)	5,492 mm (18 ft 0 in.)
<b>Tires</b>	
15.5x25 Bias (L2)	
17.5x25 Bias (L2) and 17.5x25 Bias (L3)	
17.5R25 Radial 1STAR	

PowerTech is a trademark of Deere & Company.

TX,115,JC1761 -19-22SEP98-2/2

### Drain and Refill Capacities—444H

Specification	
Cooling System—Capacity	19 L (20 qt)
Fuel Tank—Capacity	180 L (48 gal)
Engine Crankcase and Filter—Capacity	12 L (13 qt)
Transmission Case and Filter—Capacity	20 L (21 qt)
Front and Rear Differential—Capacity	19.4 L (20.5 qt)
Hydraulic Reservoir and Filters—Capacity	106 L (28 gal)
Park Brake—Capacity	0.300 L (10 oz)

TX,115,JC1866 -19-17FEB97-1/1

**TC44H Specifications**

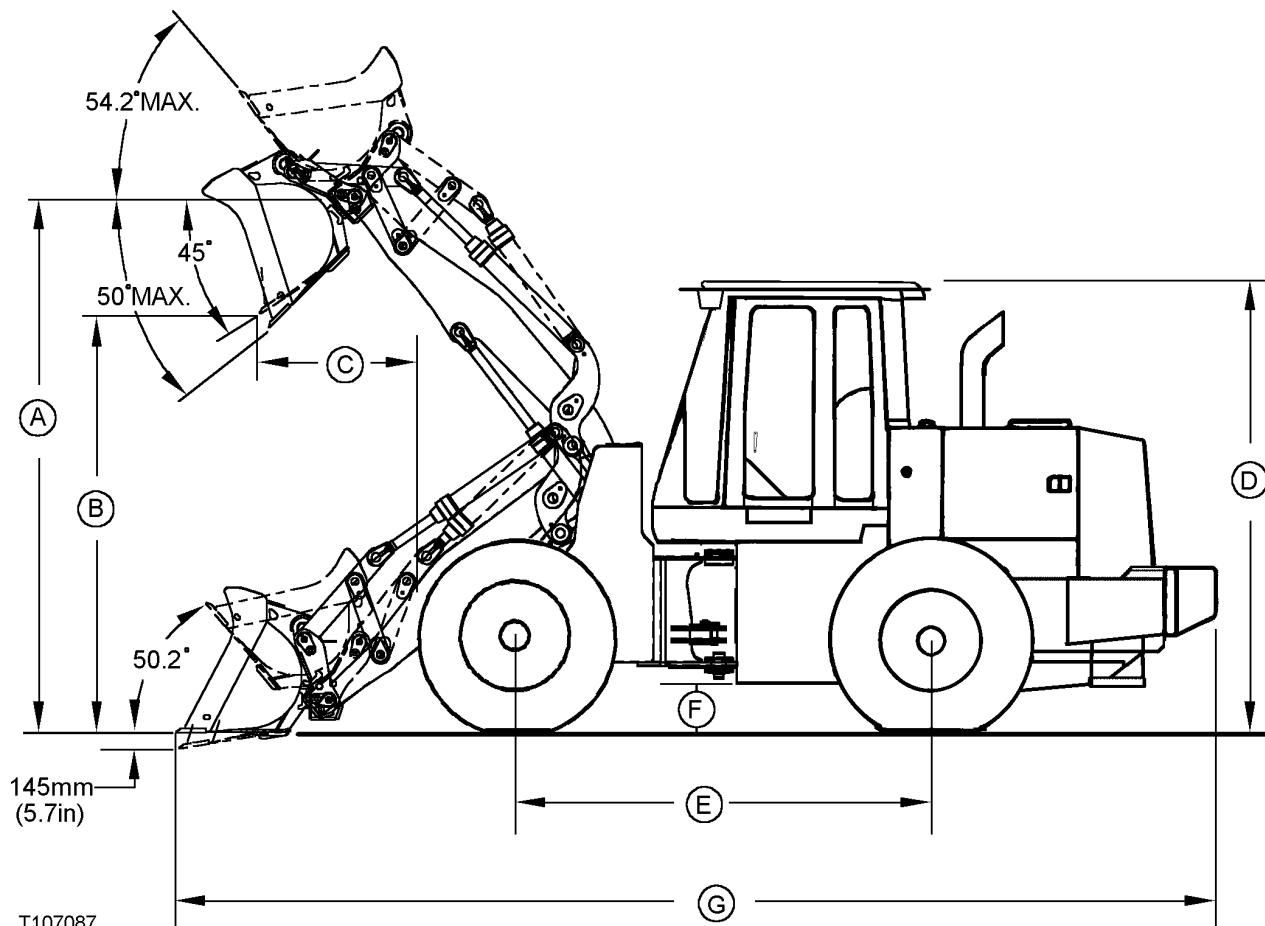

A—Bucket Hinge Height  
B—Dump Height

C—Dump Reach  
D—Overall Height

E—Wheelbase  
F—Ground Clearance

G—Overall Length

Item	Measurement	Specification
Bucket Hinge	Height (A)	3682 mm (12 ft 1 in.)
Dump	Height (B)	2676 mm (8 ft 9 in.)
	Reach (C)	1258 mm (4 ft 1 in.)
Machine	Height (D)	3125 mm (10 ft 3 in.)
	Length (G)	6969 m (22 ft 10 in.)
Wheelbase	Length (E)	2750 mm (9 ft 1 in.)
Machine-to-Ground	Clearance (F)	355 mm (14 in.)
Standard Operating	Weight	22 517 kg (10,212 lb)
Optional Counterweight	Weight	381 kg (840 lb)

**NOTE:** Specifications and design subject to change without notice. Wherever applicable, specifications are in accordance with SAE standards. Except where otherwise noted, specifications are based on a machine equipped with all standard equipment,

with 381 kg (840 lb) optional counterweight, ROPS cab, diff lock front axle with standard rear axle, 2 spool valve with two lever control, heater and defroster, 79 kg (175 lb) operator and full fuel tank.

Continued on next page

TX,115,JC1867 -19-22SEP98-1/2

T-107067—UN—20FEB97

## General Specifications

<b>Engine:</b>		
John Deere PowerTech® 4.5 turbocharged and aftercooled diesel	110 SAE net hp (82 kW) @ 2200 rpm	
	116 SAE gross hp (86 kW) @ 2200 rpm	
Piston displacement	4.5 L (276 cu in.)	
Air cleaner w/safety element and restriction indicator	Dual stage dry type with restriction indicator	
Electrical system	24 volt batteries 55-amp alternator	
Cold cranking capacity at -18°C (0°F)	625 amps	
Reserve capacity	160 min.	
Torque Converter	Single phase, single stage	
<b>Transmission</b>	Countershaft, computer controlled powershift	
<b>Travel Speeds:<sup>a</sup></b>		
<b>Forward Speeds:</b>	<b>km/h</b>	<b>mph</b>
1	0—7.5	0—4.6
2	0—13.4	0—8.3
3	0—24.9	0—15.5
4	0—40.0	0—24.8
<b>Reverse Speeds:</b>	<b>km/h</b>	<b>mph</b>
1	0—7.9	0—4.9
2	0—14.1	0—8.7
3	0—26.3	0—16.3

<sup>a</sup>All travel speeds are with 17.5 x 25 12PR (L2) tires.

<b>Brakes, Service:</b>	
Hydraulically-actuated, 4-wheel, inboard-mounted, wet disk	
Foot-operated, by either pedal	
Left and right pedal also disconnects transmission (if selected by operator)	
External inspection	
Low brake pressure warning light and buzzer in monitor	
<b>Brakes, Park:</b>	
Multi wet disc	
Spring applied, hydraulically released parking brake is bathed in cooling oil	
Transmission disconnects with park brake applied	
Warning light in monitor—Dual-level	
Amber lights with transmission in neutral	
Red STOP indicator lights, and buzzer sounds with transmission in gear	
<b>Steering:</b>	
Fully hydraulic. Frame articulated 80° by two hydraulic cylinders	
Turning radius (to corner of bucket)	5,579 mm (18 ft 3.5 in.)
<b>Tires</b>	
15.5x25 Bias (L2)	
17.5x25 Bias (L2) and 17.5x25 Bias (L3)	
17.5R25 Radial 1STAR	

PowerTech is a trademark of Deere & Company.

TX,115,JC1867 -19-22SEP98-2/2

### Drain and Refill Capacities—TC44H

Specification	
Cooling System—Capacity	19 L (20 qt)
Fuel Tank—Capacity	180 L (48 qt)
Engine Crankcase and Filter—Capacity	12 L (13 qt)
Transmission Case and Filter—Capacity	20 L (21 qt)
Front and Rear Differential—Capacity	19.4 L (20.5 qt)
Hydraulic Reservoir and Filters—Capacity	106 L (28 gal)
Park Brake—Capacity	0.300 L (10 oz)

TX,115,JC1897 -19-20FEB97-1/1